

INSTALLATION MANUAL FOR NAVARA

Installation Time (Hours):

0.5

1

2

3

Professional installation recommends

Tools:

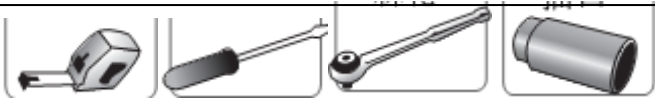

12mm 13mm



Attention:

We highly recommend you to find professional store to install the product.

Attention:

If not follow the instruction may damage the ECU, motor or the car.

INSTALLATIONAL MANUAL FOR NAVARA

COMPONENTS LIST



Running board, 2pcs



ECU



Motor bracket 2 pcs



Idler brackets 4 pcs



OBD KIT 1 SET

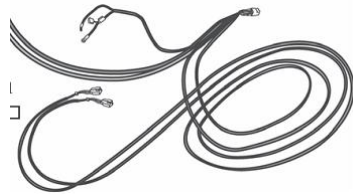

Wire harness: one set for motor power and signal



N6*25 socket cap screw ,12pcs



M10 nut w conical Washer, 8 pcs



M10 spring washer, 8pcs



U shape washer,10pcs



M8 washer, 12pcs



Plastic Line, 1 pc



Tie wire ,20 pcs

Screw Package

INSTALLATIONAL MANUAL FOR NAVARA

1. Install ECU, OBD and wiring



1) take out fuse



2) connect power wire to battery: red one with fuse is positive.



3) **CAUTION!:** Tighten battery screw very tight! If loose, may get damage to the car



4) The left motor line from above position to the leaf plate



5) The left motor line as above to the chassis and connect with motor



6) The right motor line goes to the right

INSTALLATIONAL MANUAL FOR NAVARA



7) the right motor line pass through here to the chassis. Same as left.



8) three lines from above position to co-drive position: positive line, another terminal of left and right motor line.



9) another terminal line of left and right motor line as above picture.



10) insert those 3 lines connector and with tape protected. **Connector inside th car to anti the water!**



11) The negative connect above position to get power.



12) The ECU is fixed as above

INSTALLATIONAL MANUAL FOR NAVARA



13) Plug in the OBD connector

14) Connect motor connectors and use tape to protect, connect OBD line with ECU connector, insert fuse to test if motor work well

INSTALLATIONAL MANUAL FOR NAVARA

2. Install bracket (right side)

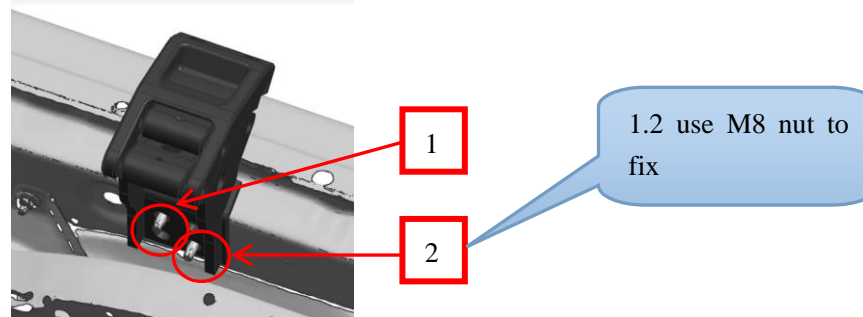
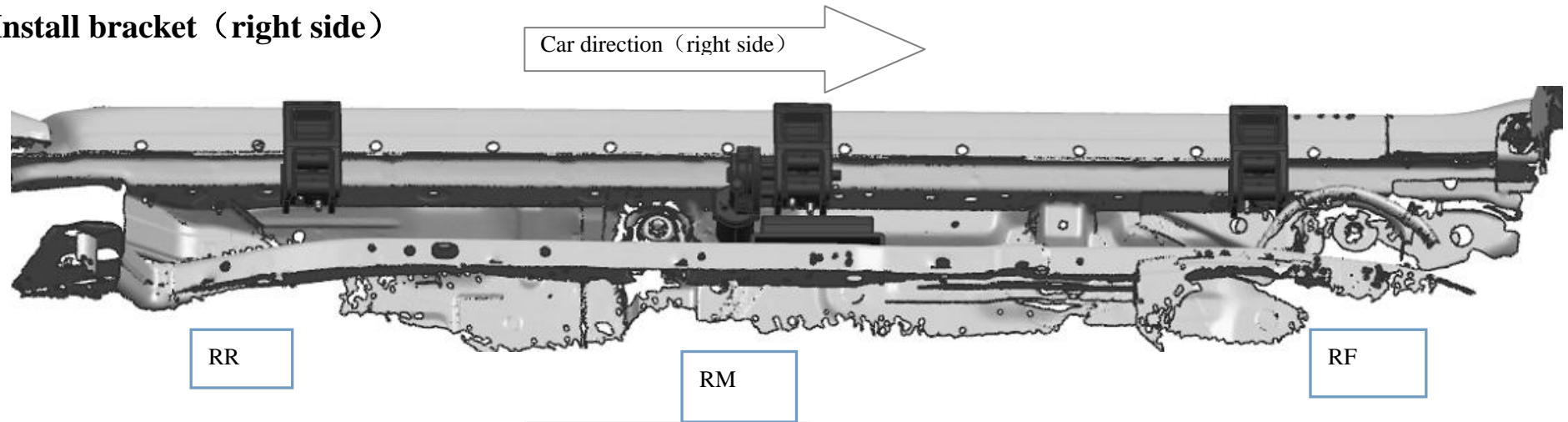

KEEP ALL SCREWS A LITTLE LOOSE, SO THAT BRACKET CAN MOVE WITH RUNNING BOARD!!!

INSTALLATIONAL MANUAL FOR NAVARA

3.Install Bracket (Left side)

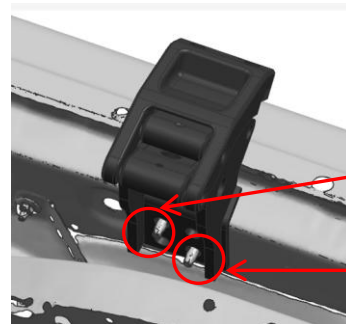
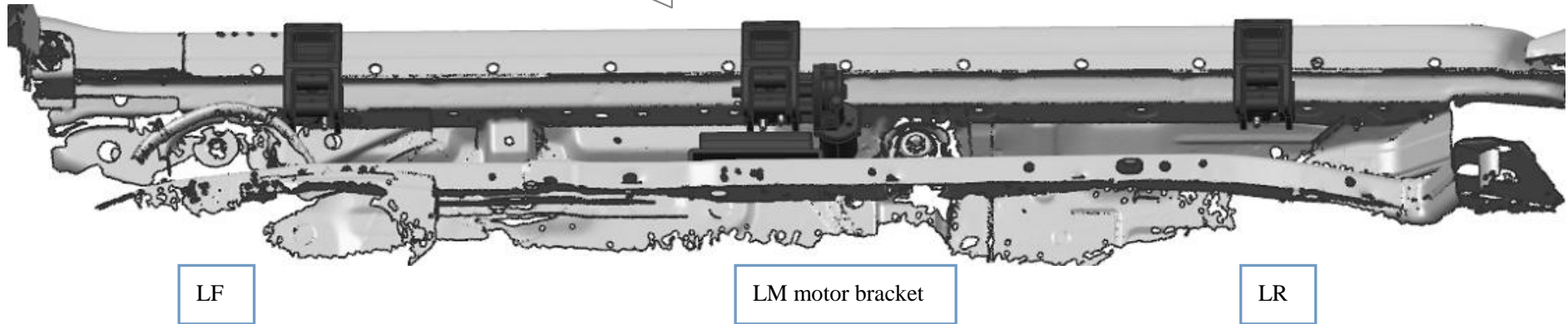
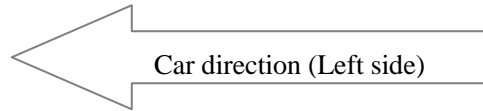

3.4 use M8 nut to fix

KEEP ALL SCREWS A LITTLE LOOSE, SO THAT BRACKET CAN MOVE WITH RUNNING BOARD!!!

INSTALLATIONAL MANUAL FOR NAVARA

4. install running board (left and right side are in same way)

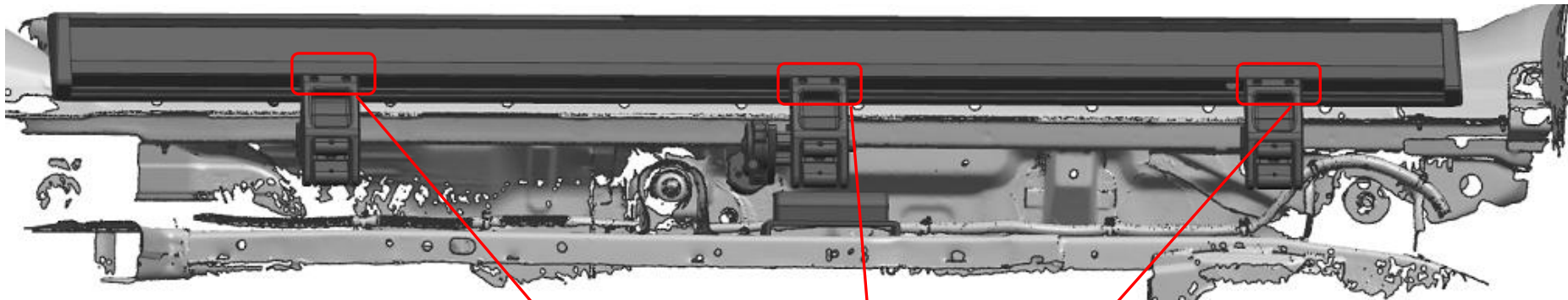

Use M6x25 screw and spring washers to fix running board with brackets.

TIGHTEN SCREWS!!

INSTALLATIONAL MANUAL FOR NAVARA

5. Testing and adjust the balance



Insert fuse again. Then open and close doors to let step work. To assure them up and down freely to adjust position by itself.

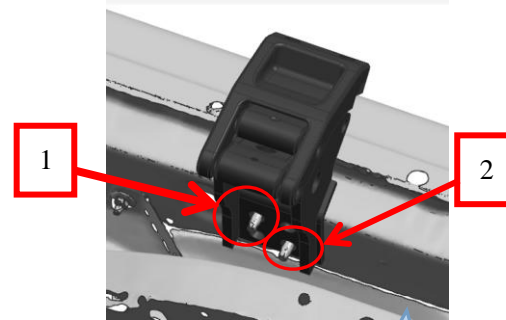

**FASTEN ALL THE SCRWS (6x2=12)
ON THE 6 BRACKETS**

If still not balance, use U shape washer to adjust it.

INSTALLATIONAL MANUAL FOR NAVARA

6. Checking all doors activate, the side step work when doors open and close.



Now the installation is finished. Protect all connectors with tap to avoid loose.



To lift the car
as showed



To lift the car

INSTALLATIONAL MANUAL FOR NAVARA



To changing tire

Automatic power deploy:

The running boards will extend down and out when the door is opened.

Automatic stop:

If an object is in the way of the moving running board, the running board will automatically stop. To reset, clear any obstruction, then simply open and close the door to resume normal operation.

Manually set in the deployed (OUT) position for access to the roof:

Step your foot while at the same time closing the door. To resume normal operation, open and close the door.

Maintenance: In adverse conditions, debris such as mud, dirt, and salt may become trapped in the running board mechanism, possibly leading to unwanted noise. If this occurs, manually set the running boards to avoid spraying the motors directly. After washing, apply silicone spray lubricant to the hinge pivot pins.

Caution! Keep hands and feet away when the running board is in motion.